

COMPANY NAME (LESSEE OR OWNER)

PHONE

INSP. TYPE INITIAL RENEWAL

INSPECTION DATE 3/4/00

COMPANY ADDRESS AND ZIP

COMPANY NAME, LAST INSPECTION SAME

DATE OF LAST INSPECTION

CARRIER DATA

MAKE Grove SERIAL NO. 52008187 LICENSE NO. 4WFE645 COMPANY NO. 11179 FUEL LEVEL 100% FRONT BUMPER CWT: OPERATES REMOVED ATTACHED W/O

UPPER WORKS DATA

MAKE Grove MODEL G MK 5200 SERIAL NO. 5200 8187 WEIGHT CLASS (TONS) 240 FUEL LEVEL: 100% DISTANCE FROM Q OF UPPER WORKS ROTATION TO C REARMOST CARRIER AXLE: 5 FT. 7 IN.

ACCESSORIES CARRIED ON TRUCK CRANE NONE LIST FOLLOWING

- 1. Out Rigger Pads 2. 3. 4. 5. 6.

BOOM SUPPORT VEHICLE DATA

LICENSE NO. 4AR5955 TIRES: 235 SIZE 25R17.5; CAP. 5675 lbs VEH. WIDTH: 8 FT. 0 IN BOOM SUPPORT VEHICLE LENGTH W/O TOWBAR 26 FT. 9 IN.

ACCESSORIES CARRIED ON BOOM SUP. VEH. NONE LIST FOLLOWING

- 1. 2. 3. 4. 5. 6.

VEHICLE DESCRIPTION

MAX. HEIGHT OF ANY CARRIER OR CRANE COMPONENT: 13 FT. 8 IN. 1/ MAX. WIDTH OF CARRIER OR CRANE INCL ALL PROJECTIONS EXCEPT LIGHTS, MIRRORS, & EQUIPMENT DEFINED IN VC35110: 10 FT. 0 IN.

CARRIER LENGTH: 44 FT. 6 IN. OVERALL VEHICLE COMBINATION LENGTH: 74 FT. 3 IN. OV'LL LENGTH INCL BOOM 79 FT. 4 IN.

Table with columns: AXLE NUMBER, NO. OF TIRES, AXLE SPACING, O-O OF TIRES, SCALE WEIGHT, PERMIT WEIGHT. Rows 1-9.

BOOM INFORMATION

BOOM TYPE AND DESCRIPTION LATTICE BUTT INTER. SECT. TIP TELESCOPING JIB ATTACHED

BOOM LENGTH Q ROTATION TO LAST HARD METAL 45 FT. 3 IN. BOOM END ATTACHMENTS: BLOCK SIZE 25 (TONS)

FRONT BOOM OVERHANG FRONT OF TIRES TO TIP CLR. FROM ROADWAY TO BOOM BALL SIZE 0 (DIAM.)

REAR BOOM OVERHANG UNSUPPORTED: FROM Q REAR CARRIER AXLE TO TIP PT OF LAST SUPPORT TO TIP LEGAL PERMIT

PERMIT DATA (Permit Office Use Only)

1. Qualified for Weight Transfer or Bonus: YES NO 2. Tire Ratings Limit Permitted Weights: YES NO 3. Routing Weight Class: LEGAL GREEN PURPLE ANNUAL 4. Permit Classification Eligibility: SINGLE TRIP ONLY

CALTRANS REPRESENTATIVE: Bill Collins TITLE Permit Vehicle Insp

Remarks:

TRUCK CRANE PROFILE SHEET

5 4/86

DATE 3/4/88

ATTACHMENT TO PERMIT NO. _____

MAKE AND MODEL Grove GMK 5200
COMPANY NO. 11179
LICENSE NO. 4WEE695

THIS DRAWING IS A GENERAL CONFIGURATION ONLY

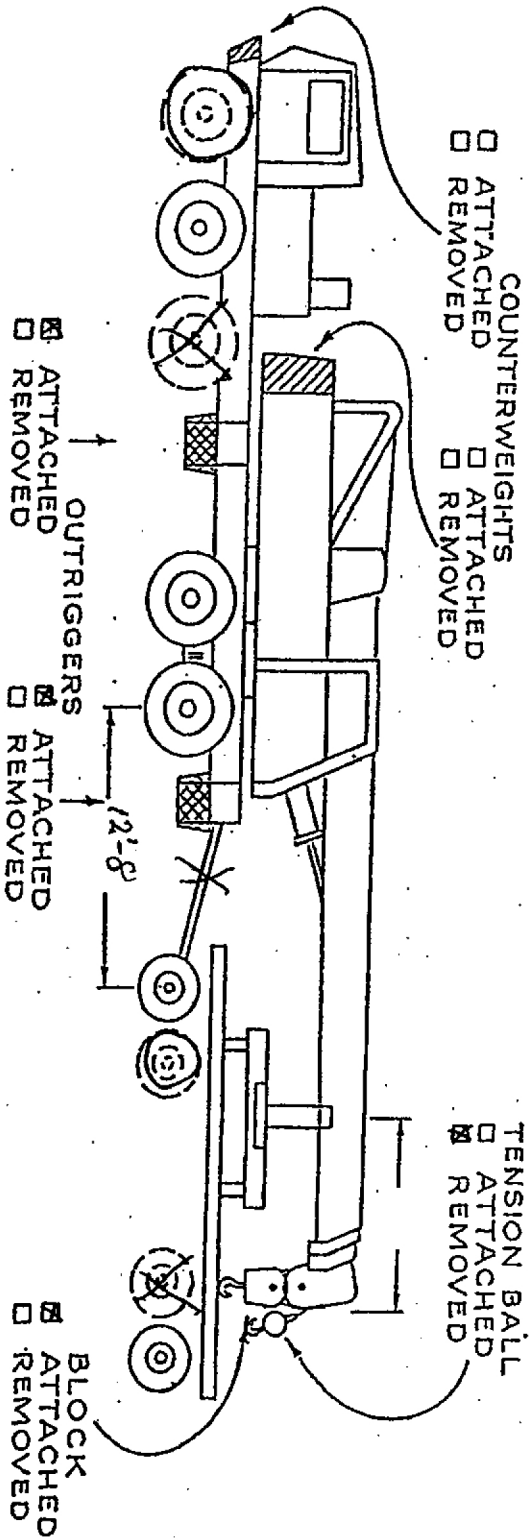

COUNTERWEIGHTS
 ATTACHED
 REMOVED

TENSION BALL
 ATTACHED
 REMOVED

OUTRIGGERS
 ATTACHED
 REMOVED

BLOCK
 ATTACHED
 REMOVED

WHEN THE ABOVE CONFIGURATION AND DIMENSIONS ARE ADHERED TO THIS VEHICLE SHOULD NOT EXCEED PERMITTED WEIGHTS

MAXIMUM FUEL ALLOWED
UPPERWORKS 100
CARRIER 100

EQUIPMENT CARRIED ON CARRIER
EQUIPMENT CARRIED ON TRAILER

None
None

#11179 2002 Grove GKM5240 240-ton
 sn 52008187

10' 1" Wide on carrier / 7' 10" wide on dolly

Under 14' high - LEGAL

Weights with jib and 100% fuel on upper and lower – no 2nd winch and no counterweight – single sheave block on line.

CAT scale weights ticket #72346228

18,180#

32,320#

50,900#

48,460#

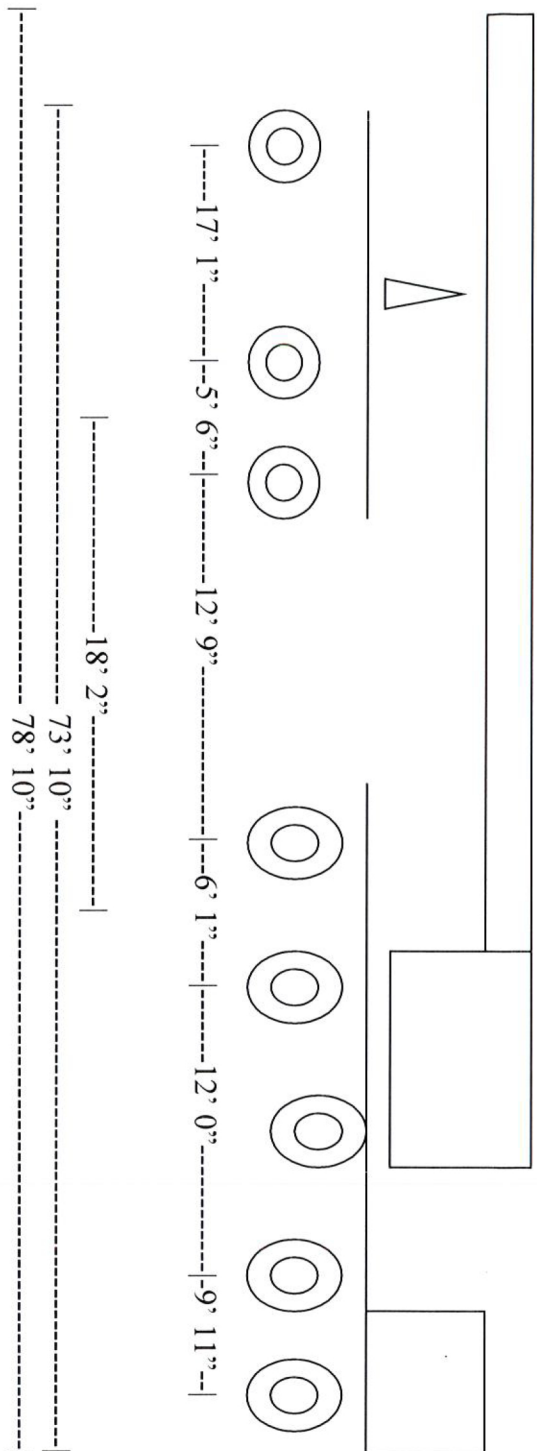

235/75R17.5 (9.25" wide tire)
 (12 total / 4 on each axle / Last axle is steer)

20.5R25 (525/80R25) (20.5" wide tire)
 (8 total on ground / 2 on each axle / ALL steer)