

Specifications

Hydraulic Lattice Boom Truck Crane

HC-248H

200-Ton (181.50 metric ton)

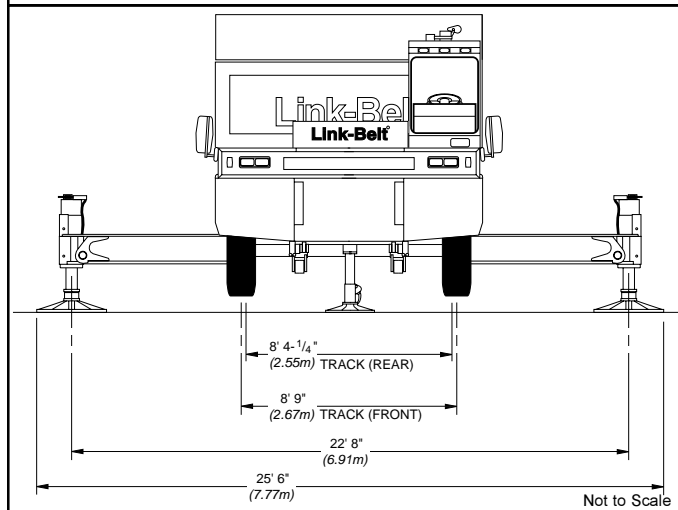
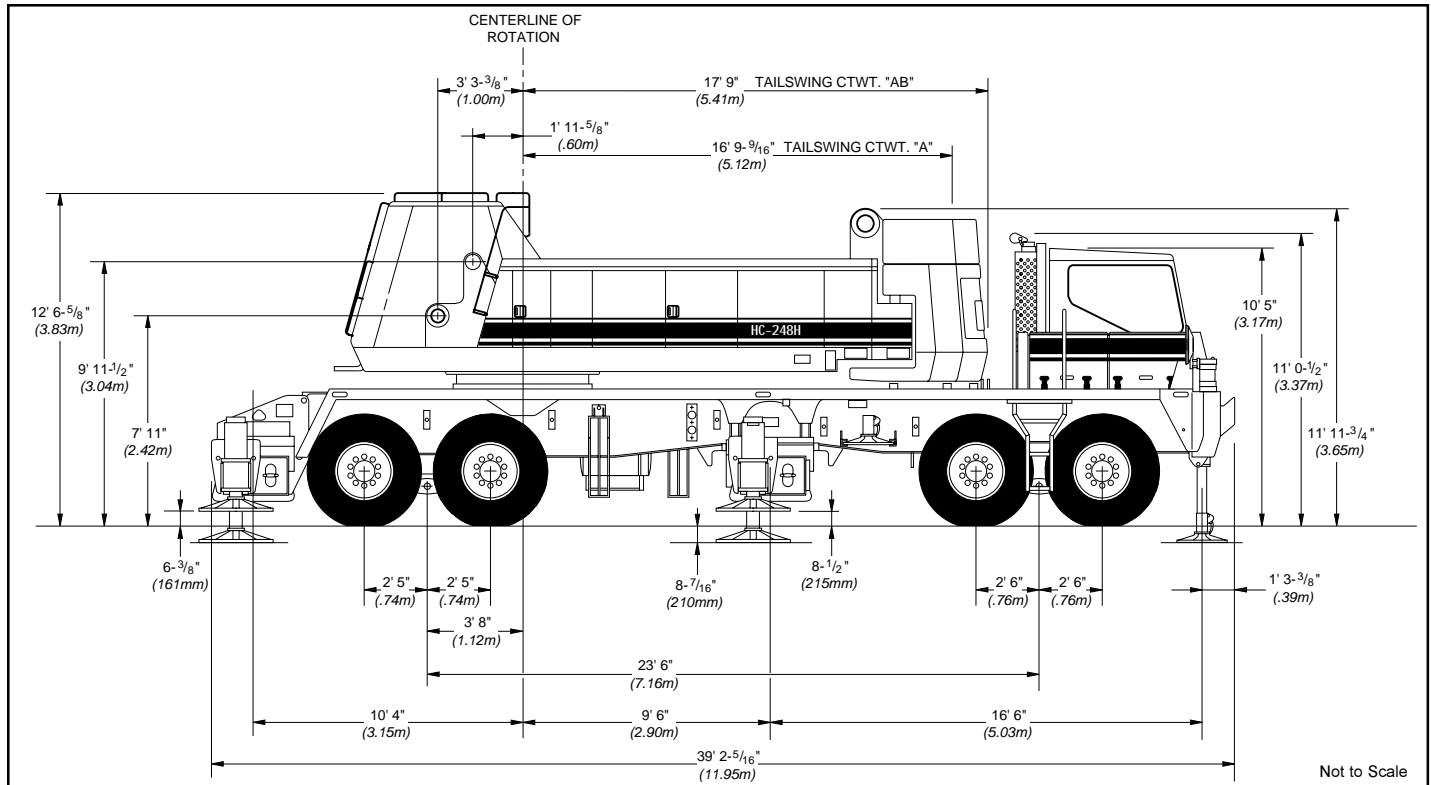

| General dimensions | Feet | meters |
|---|----------|--------|
| Overall width, outriggers retracted (floats removed) | 11' 0" | 3.35 |
| Minimum ground clearance (at bottom of front bogie beam) | 11" | .28 |
| Ground clearance under counterweight with machine on tires | 5' 8.75" | 1.75 |
| Overall cab width (upper) | 11' 0" | 3.35 |
| Radius of boom hinge pin | 3' 3.4" | 1.00 |
| Vehicle turning diameter - Centerline outside front tire | 106' | 32.30 |
| Vehicle turning diameter - Outside of outer front tire (curb clearance) | 107' 3" | 32.69 |
| Vehicle clearance over front bumper | 111' 8" | 34.03 |
| Vehicle clearance over "A" front bumper ctwt | 113' 2" | 34.49 |
| Vehicle clearance over "AB" front bumper ctwt | 113' 10" | 34.70 |

Boom, Live Mast and Jib

■ Tubular Boom

Basic Boom – Two-piece 50' (15.24 m) long. Each section is 80" (2.03 m) wide by 68" (1.73 m) deep at the connections. Chords are 4" (.10 m) diameter alloy steel.

Boom Connections – In-line pin connections.

Base Section – 20' (6.10 m) long with the boomfeet on 55.12" (1.40 m) centers.

Boom Extensions – Available in 10', 20', 30', 40' and 50' (3.05, 6.10, 9.14, 12.19 and 15.24 m) lengths with appropriate length pendants. Maximum boom length combination is 280' (85.34 m).

Boom Extension with lifting Sheaves – An optional 10' (3.05 m) long section with lifting sheaves is designed to assist in the assembly and disassembly of the counterweights and outriggers.

Tip Section – 30' (9.14 m) long with open-throat top section.

Boompont Machinery – Six 20.75" (.53 m) root diameter sheaves mounted on sealed anti-friction bearings for lift crane applications.

Boom Angle Indicator – Pendulum type mounted on boom base section.

■ Boom Live Mast

Standard – 30' (9.14 m) long supports the boomhoist bridle and boom pendants, and is required for all boom lengths and combinations. May be used in the assembly and disassembly of the boom, counterweights and outriggers, but not intended for lift crane service.

Note: The mast may be self-stored either over the rear or the front of the upperstructure to help meet weight restriction when traveling.

Optional (Live Mast Weight Transfer System) – Hydraulic cylinders position the live mast over the rear of the upperstructure to transfer weight from one axle group to the other.

■ Tubular Jib

Basic Jib – Two-piece 30' (9.14 m) long. Each section is 32" (.81 m) wide by 24" (.61 m) deep at the connections. Chords are 2.25" (.57 mm) diameter alloy steel.

Jib Connections – In-line pin connections.

Jib Offsets – All jib length combinations can be offset to 5, 15 and 25 degrees.

Base Section – 15' (4.57 m) long.

Jib Extensions – Available in 10' and 20' (3.05, and 6.10 m) lengths with appropriate length pendants. Maximum jib length combination is 100' (30.48 m). Maximum boom plus jib combination is 240' (73.15 m) plus 100' (30.48 m).

Tip Section – 15' (4.57 m) long is equipped with a single peak 21" (.53 m) root diameter sheave. The sheave is mounted on sealed anti-friction bearings for lift crane applications. An anchor is provided at the peak for two-part load hoist wire rope (whipline) connection.

Jib Mast – 17'10" (5.44 m) long is mounted on the jib base section. A deflector sheave is mounted within the mast to guide the whipline. Two equalizer sheaves are mounted to the top of the mast – one for the front stayline and the other for the back stayline. All sheaves are mounted on sealed anti-friction bearings for lift crane applications.

Jib staylines – The back staylines vary in length depending on the degree of jib offset from the boom centerline and attaches at the bottom end of the boom top section. The front staylines vary in length depending on the length of the jib.

Jib stops – Telescoping type, pinned from jib mast to boom top section and from jib mast to jib base section.

Upperstructure

■ General

Frame – High strength alloy steel.

Machinery Cab – Hinged doors (one on right side and two on the left side) for machinery access. Equipped with rooftop access ladder, electric warning horn and skid-resistant finish on roof.

Catwalks – Standard on operator's side. Catwalks remove to reduce travel width.

Bail – Mounted on sealed anti-friction bearings, seven sheaves are provided for 16 part boom hoist wire rope reeving.

■ Swing

Independent, an axial piston motor through a gear reduction system drives hydraulic swing. Free swing when lever is in neutral position.

Swing Brake – 360 degree; spring applied, hydraulically released; electrically controlled by a button on the swing control lever.

Travel Swing Lock – Two position locking mechanism mechanically controlled from the operator's cab.

Turntable bearing – Inner race with integral swing (race) gear mounted on carrier.

Swing Speed – Variable from 0 to 2 rpm

■ Load Hoist System

Mounted on sealed anti-friction bearings, the main (front) and auxiliary (rear) hoists are 19" (.48 m) root diameter grooved for 1" (25 mm) wire rope. Each drum is reduction geared and powered by a fixed displacement axial piston motor. Actuating or reversing the hydraulic motor provides load hoisting or lowering. Smooth, precise power load lowering is attained with an automatic hydraulic brake. The operator control levers provides two speeds for hoisting and lowering. Additional, each drum is equipped with audible-type rotation indicators.

Drum Clutches – Speed-o-Matic power two-shoe clutches; 30" (.76 m) diameter, 6.5" (.17 m) width; internal expanding, lined shoes. Clutch spiders are splined to shafts; clutch drums are integral with hoist drums.

Freefall – For use in high cycle and duty cycle applications, hydraulic controlled two-shoe clutches allow freefall operation of the main and auxiliary hoist drums. Electrically activated by a mode selection switch in the operator's cab.

Drum Brakes – External contracting band-type; operated by foot pedal equipped with a locking latch. Operator may select automatic brake mode* (spring applied, hydraulic release), which will apply brakes when the hoist lever is in the neutral position.

*Automatic brake mode meets all OSHA requirements for personnel handling.

Drum Locking Pawls – Electrically actuated and prevents drum rotation in a load lowering condition.

■ Load Hoisting Performance

Available line speed and line pull

Line pulls are not based on wire rope strength. See wire rope chart below for maximum permissible single part of line working loads.

Line Speeds and Pulls

| Rope layer | Front Drum - 1" (25 mm) wire rope | | | | | | Rear Drum - 1" (25 mm) wire rope | | | | | |
|------------|-----------------------------------|--------|--------------------|-------|----------------------|-------|----------------------------------|--------|--------------------|-------|----------------------|-------|
| | Maximum line pull | | No load line speed | | Full load line speed | | Maximum line pull | | No load line speed | | Full load line speed | |
| | lbs. | kg | ft./min | m/min | ft./min | m/min | lbs. | kg | ft./min | m/min | ft./min | m/min |
| 1 | 48,622 | 22 055 | 225 | 68 | 112 | 34 | 29,361 | 13 318 | 372 | 113 | 186 | 57 |
| 2 | 44,198 | 20 048 | 247 | 75 | 124 | 38 | 26,689 | 12 106 | 410 | 125 | 205 | 62 |
| 3 | 40,512 | 18 376 | 270 | 82 | 135 | 41 | 24,463 | 11 096 | 447 | 136 | 223 | 68 |
| 4 | 37,393 | 16 961 | 292 | 89 | 146 | 45 | 22,580 | 10 242 | 484 | 148 | 242 | 74 |
| 5 | 34,720 | 15 749 | 315 | 96 | 157 | 48 | 20,966 | 9 510 | 521 | 159 | 260 | 79 |
| 6 | 32,404 | 14 698 | 337 | 103 | 169 | 51 | 19,567 | 8 876 | 559 | 170 | 279 | 85 |
| 7 | 30,378 | 13 779 | 360 | 110 | 180 | 55 | 18,344 | 8 321 | 596 | 182 | 298 | 91 |

| Rope layer | Boomhoist Drum - 7/8" (22 mm) wire rope | | | | | | Third Drum - 1" (25 mm) wire rope | | | | | |
|------------|---|--------|--------------------|-------|----------------------|-------|-----------------------------------|-------|--------------------|-------|----------------------|-------|
| | Maximum line pull | | No load line speed | | Full load line speed | | Maximum line pull | | No load line speed | | Full load line speed | |
| | lbs. | kg | ft./min | m/min | ft./min | m/min | lbs. | kg | ft./min | m/min | ft./min | m/min |
| 1 | 40,842 | 18 526 | 147 | 45 | 134 | 41 | 20,656 | 9 369 | 442 | 135 | 105 | 32 |
| 2 | 36,760 | 16 674 | 163 | 50 | 149 | 45 | 18,752 | 8 506 | 486 | 148 | 116 | 35 |
| 3 | 33,417 | 15 158 | 180 | 55 | 163 | 50 | 17,169 | 7 788 | 531 | 162 | 127 | 39 |
| 4 | 30,633 | 13 895 | 196 | 60 | 178 | 54 | 15,833 | 7 182 | 576 | 176 | 138 | 42 |
| 5 | 28,276 | 12 826 | 213 | 65 | 193 | 59 | 14,690 | 6 663 | 621 | 189 | 148 | 45 |
| 6 | 26,257 | 11 910 | 229 | 70 | 208 | 63 | -- | -- | -- | -- | -- | -- |
| 7 | 24,506 | 11 116 | 245 | 75 | 223 | 68 | -- | -- | -- | -- | -- | -- |

Wire Rope Drum Capacities

| Rope layer | Boomhoist Drum Capacity - 7/8" (22 mm) wire rope | | | | | |
|------------|--|-------|-------|------|-------|-------|
| | Pitch Diameter | | Layer | | Total | |
| | in. | mm | ft. | m | ft. | m |
| 1 | 15.88 | 403.2 | 51.8 | 15.8 | 51.8 | 15.8 |
| 2 | 17.63 | 447.7 | 57.1 | 17.4 | 108.9 | 33.1 |
| 3 | 19.38 | 492.1 | 62.3 | 19.0 | 171.2 | 51.9 |
| 4 | 21.13 | 536.6 | 67.2 | 20.3 | 238.5 | 72.4 |
| 5 | 22.88 | 581.0 | 72.5 | 22.0 | 311.0 | 94.4 |
| 6 | 24.63 | 625.5 | 77.4 | 23.4 | 388.4 | 117.8 |
| 7 | 26.38 | 669.9 | 82.7 | 25.1 | 471.1 | 142.9 |

| Rope layer | Front Drum Capacity - 1" (25 mm) wire rope | | | | | |
|------------|--|-----|-------|------|-------|-------|
| | Pitch Diameter | | Layer | | Total | |
| | in. | mm | ft. | m | ft. | m |
| 1 | 20 | 508 | 110 | 33.4 | 110 | 33.4 |
| 2 | 22 | 559 | 121 | 36.7 | 230 | 69.3 |
| 3 | 24 | 610 | 132 | 40.0 | 362 | 109.9 |
| 4 | 26 | 660 | 143 | 43.4 | 504 | 152.9 |
| 5 | 28 | 711 | 154 | 46.7 | 658 | 199.7 |
| 6 | 30 | 762 | 164 | 49.7 | 822 | 249.5 |
| 7 | 32 | 813 | 175 | 53.1 | 998 | 302.9 |

| Rope layer | Rear Drum Capacity - 1" (25 mm) wire rope | | | | | |
|------------|---|-----|-------|------|-------|-------|
| | Pitch Diameter | | Layer | | Total | |
| | in. | mm | ft. | m | ft. | m |
| 1 | 20 | 508 | 110 | 32.4 | 110 | 32.4 |
| 2 | 22 | 559 | 121 | 36.7 | 230 | 69.3 |
| 3 | 24 | 610 | 132 | 40.1 | 362 | 110.3 |
| 4 | 26 | 660 | 143 | 43.4 | 504 | 153.6 |
| 5 | 28 | 711 | 154 | 46.7 | 658 | 200.6 |
| 6 | 30 | 762 | 164 | 49.8 | 822 | 250.5 |
| 7 | 32 | 813 | 175 | 53.1 | 998 | 302.9 |

| Rope layer | Third Drum Capacity - 1" (25 mm) wire rope | | | | | |
|------------|--|-----|-------|------|-------|-------|
| | Pitch Diameter | | Layer | | Total | |
| | in. | mm | ft. | m | ft. | m |
| 1 | 19.7 | 500 | 150 | 45.5 | 150 | 45.5 |
| 2 | 21.7 | 551 | 165 | 50.1 | 316 | 95.9 |
| 3 | 23.7 | 602 | 181 | 54.9 | 496 | 150.5 |
| 4 | 25.7 | 653 | 196 | 59.4 | 692 | 210.0 |
| 5 | 27.7 | 704 | 211 | 64.0 | 903 | 274.1 |

Wire Rope: size, type and working strength

| Wire rope application | Size: diameter | | Type | Max. permissible load | |
|--------------------------|----------------|----|------|-----------------------|-------|
| | inches | mm | | lbs. | kg |
| Boomhoist | 7/8 | 22 | LB | 25,000 | 11340 |
| Main load hoist | 1 | 25 | LB | 32,500 | 14740 |
| Jib load hoist (1-part) | 1 | 25 | RB | 22,760 | 10320 |
| Jib load hoist (2-parts) | 1 | 25 | RB | 45,520 | 20640 |
| Boom pendants (dual) | 1 | 25 | N | N/A | N/A |
| Jib staylines | 7/8 | 22 | N | N/A | N/A |

Wire Rope: types available

- Type "N" - 6 x 25 (6 x 19 class) filler wire, extra improved plow steel, preformed, independent wire rope center, right lay, regular lay.
- Type "LB" - 6 strand, compacted strand, Seale or Warrington Seale, preformed, independent wire rope center, right lay, regular lay.
- Type "RB" - Rotation resistant, 19 strand, Compacted strand, Extra-extra improved plow steel, preformed, right regular lay.

Upperstructure

■ Boom Hoist System

Mounted on sealed anti-friction bearings, the boom hoist drum is 15" (.38 m) root diameter grooved for 7/8" (22 mm) wire rope. The drum is independently driven by an axial piston motor through a gear reduction system. Boom lowering is preformed by actuating or reversing the piston motor. Boom hoist speed from 0 to 70 degrees boom angle is 90 seconds.

Boom Hoist Brake – Spring applied, hydraulic release, which will apply the brake when the boom hoist lever is in the neutral position.

Drum Locking Pawl – Electrically actuated and prevents drum rotation in a boom lowering condition.

Boom Hoist Limiting Device – Restricts boom from being hoisted beyond recommended minimum radius.

■ Hydraulic System

Main Pumps – Two variable displacement piston pumps operating at 4,000 psi (281.24 kg/cm²) power main drum, auxiliary drum and boom hoist drum. Two fixed displacement gear pumps operating at 3,000 psi (211 kg/cm²) power swing function. One fixed displacement gear pump operating at 1,210 psi (85 kg/cm²) powers pilot control system, clutches, brakes and pump controls.

Pump Control ("Fine Inching") mode – Special fine metering pump setting, selectable from the operator's cab, allows very slow movements to the main hoist, auxiliary hoist and boom hoist for precision work.

Hydraulic Reservoir – 42 gallons (158 L) capacity equipped with sight level gauge. Diffusers built in for deaeration.

Filtration – One 10 micron, full flow, line filter in the control circuit. All oil is filtered prior to return to sump tank.

Counterbalance Valves – All hoist motors are equipped with counter-balance valves to provide load lowering and prevents accidental load drop when hydraulic power is suddenly reduced.

■ Pump Drive

All functions are hydraulically powered allowing positive, precise control with independent or simultaneous operation of all functions.

■ Electrical

Two batteries provide 24-volt operating and starting.

Swing Alarm – Audio/visual warning device signals when upper is swinging.

Lights – Two 70 watt sealed beam on the front of the upper superstructure.

■ Fuel Tank

One 76 gallon (288 liter) capacity tank.

■ Counterweight

Standard - Three-piece "ABC" counterweight consisting of 23,000 lbs. (10 433 kg) "A" counterweight, 19,330 lbs. (8 768 kg) "B" counterweight, and 21,110 lbs. (9 575 kg) "C" counterweight. Total weight - 64,440 lbs. (29 229 kg).

* See carrier section for carrier counterweights.

Operators Cab

Fully enclosed, one person. Galvaneal steel construction lined with vinyl covered acoustical insulation.

Equipped with:

- Swing-up roof window
- Sliding right-side door
- Sliding tinted left-side window
- Door and window locks
- Removable catwalks
- Fire extinguisher
- Sun visor
- Dome light
- Rubber floor mat

Cab Instrumentation – The instrument panels houses:

- Service center that monitors oil filter, engine oil pressure, radiator water level, engine temperature, air cleaner, battery charge, battery fluid and swing brake.
- Switches for fine inching control, 2-speed electric windshield wiper/washer, heater, fan, working lights, ignition and drum locks.
- Bubble-type level
- Tachometer
- Voltmeter
- Fuel gauge
- Hydraulic oil temperature gauge
- Engine temperature gauge

Lever Control System – Remote controlled hydraulic servo for main and auxiliary drums. Mechanical linkage controls swing. Function speed is proportional to lever movement. Levers are adjustable for operator comfort.

Rated Capacity Limiter – PAT DS-350 audio-visual warning system with function limiters. Programmed with multiple charts it provides operator with:

- Main boom and jib angle
- Operating mode
- Load radius
- Boom tip height
- Anti-two block indicator
- Pre-warning light, audible alarm and overload light
- Allowed and actual load on hook

| Engine Specifications | Isuzu 6SD1TQB-01 |
|---|--------------------------|
| Number of cylinders | 6 |
| Bore and stroke: inch (mm) | 4.72 x 5.71 120 x 145 |
| Piston displacement - cu. in. - (cm ³) | 600 9839 |
| High idle speed - rpm | 2,400 |
| Engine rpm at full load speed | 2,200 |
| Net engine hp at full load speed - (kw) | 248 186 |
| Peak torque - foot pounds - (joules) | 644 873.3 |
| Peak torque - rpm | 1,500 |
| Electrical system | 24-volt |
| Batteries | 2 - 12 volt |

Carrier

General

11' 0" (3.35m) wide, 282" (7.16 m) wheelbase.

Standard – 8 x 4 x 4 drive.

Frame – 100,000 PSI (689.5 MPa) alloy steel, triple box construction.

Outriggers

Double-box, dual beams front and rear, pin connected to carrier frame.

Hydraulically operated beams and jack cylinders are individually controlled from each side of carrier. Single hydraulically operated front jack cylinder is individually controlled from front bumper of carrier. Each jack cylinder is equipped with integral holding valves.

Rear outriggers – Quick-attach, self-aligning system with hydraulic box pin puller and box mounting controls.

Front outriggers – Roll-out system with tilting left jack cylinder for frame clearance during box removal. Quick-attach, self-aligning system with hydraulic box pin puller and box mounting controls.

Floats - Four main stowable, quick-release, steel floats with 34" (.86 m) diameter base. A stowable, quick-release, aluminum float with 24" (.61 m) diameter base for front bumper jack.

Jack reactions – 252,000 lbs. (114 305 kg) force and 278 PSI (19.55 kg/cm²) ground bearing pressure maximum on main outriggers. 75,000 lbs. (34 019 kg) force and 167 PSI (11.74 kg/cm²) ground bearing pressure maximum on front bumper outrigger.

Steering

Sheppard full integral hydraulic power. Steering mounted on high side of frames to minimize exposure o hazards. High speed, high power system to maximize maneuverability both on the job and on the road.

Axles

Front – Tubular, bogie beam mounted, tandem axles, 105" (2.67m) track with single wheels.

Rear – Planetary, bogie beam mounted, tandem axles, 100.25" (2.56 m) track with dual wheels.

Pusher – *Optional*; 22,000 lb. (9 979 kg) rated tubular trailer axle with dual 275/70R22.5 tubeless radial tires on disc wheels and lift-type air suspension system. Axle centerline located at 91" (2.31 m) ahead of drive axle tandem centerline. 91.75" (2.33 m) track.

Suspension

Front – Air-ride system, 4-bag walking beam style that deflates to solid mount for increased stability during job site travel.

Rear – Solid mount, bronze bushed equalizer beams with rubber bushed torque rods.

Wheels

Front – Hub mounted steel disc.

Rear – Integral with planetary hubs.

Tires

Standard – 14R24 3- star radial with on-off highway tread.

Brakes

Service – Full air brakes on all wheel ends. Dual circuit with modulated emergency brakes.

Front – 16.5" x 6" (.42 m x .15 m) S-Cam brakes.

Rear – 20.25" x 7" (.42 m x .15 m) S-Cam brakes.

Parking/emergency – One spring set, air released chamber per rear axle end. Emergency brakes apply automatically when air pressure drops below 60 PSI (413.7 kPa) in both systems.

Carrier Speeds

| Main - Eaton RTO 14908LL | | | Auxiliary - Spicer P-1241-C | | | | | | | |
|--------------------------|------|-------|-----------------------------|-------|------------|------|------------|------|------------|------|
| | | | 4th (.81) | | 3rd (1.00) | | 2nd (1.24) | | 1st (2.37) | |
| Gear | | Ratio | mph | km/h | mph | km/h | mph | km/h | mph | km/h |
| High | 8th | .74 | 58.5* | 94.2* | 47.4 | 76.3 | 38.2 | 61.5 | 20.0 | 32.2 |
| | 7th | 1.00 | 43.2 | 69.5 | 35.1 | 56.5 | 28.3 | 45.5 | 14.8 | 23.8 |
| | 6th | 1.36 | 31.8 | 51.2 | 25.8 | 41.5 | 20.8 | 33.5 | 10.9 | 17.5 |
| | 5th | 1.83 | 23.6 | 38.0 | 19.2 | 30.9 | 15.5 | 24.9 | 8.1 | 13.0 |
| Low | 4th | 2.53 | 17.1 | 27.5 | 13.9 | 22.4 | 11.2 | 18.0 | 5.9 | 9.5 |
| | 3rd | 3.40 | 12.7 | 20.4 | 10.3 | 16.6 | 8.3 | 13.4 | 4.4 | 7.1 |
| | 2nd | 4.63 | 9.3 | 15.0 | 7.6 | 12.2 | 6.1 | 9.8 | 3.2 | 5.1 |
| | 1st | 6.24 | 6.9 | 11.1 | 5.6 | 9.0 | 4.5 | 7.2 | 2.4 | 3.9 |
| | L | 9.42 | 4.6 | 7.4 | 3.7 | 6.0 | 3.0 | 4.8 | 1.6 | 2.6 |
| Deep Reduction | LL | 14.56 | 3.0 | 4.8 | 2.4 | 3.9 | 1.9 | 3.1 | 1.0 | 1.6 |
| Hi Rev. | Rev. | 2.89 | 15.0 | 24.1 | 12.1 | 19.5 | 9.8 | 15.8 | 5.1 | 8.2 |
| Lo Rev. | Rev. | 9.85 | 4.4 | 7.1 | 3.6 | 5.8 | 2.9 | 4.7 | 1.5 | 2.4 |
| Deep Reduction | Rev. | 15.22 | 2.8 | 4.5 | 2.3 | 3.7 | 1.9 | 3.1 | 1.0 | 1.6 |
| Deep Reduction @ 600 rpm | LL | 14.56 | .85 | 1.4 | .7 | 1.2 | .55 | .9 | .3 | .5 |
| Deep Reduction @ 600 rpm | Rev. | 15.22 | .8 | 1.3 | .65 | 1.1 | .5 | .8 | .3 | .5 |

* Radial tires and pick and carry axles and rims required for top speeds above 50 mph (80.45 km/hr).

Carrier

■ Fuel Tank

One 85 gallon (322 liter) capacity tank.

■ Bumper Counterweight

Standard - Two-piece "AB" counterweight consisting of 13,500 lbs. (6 124 kg) "A" counterweight and 11,500 lbs. (5 216 kg) "B" counterweight. Total weight - 25,000 lbs. (11 340 kg).

Optional - One-piece "auxiliary" counterweights. Total weight - 10,000 lbs. (4 536 kg). For use with luffing boom attachment only.

■ Carrier Cab

Fully enclosed, one person. Galvaneal steel construction lined with vinyl covered acoustical insulation. Equipped with:

- Air ride seat with seat belt
- 2-speed electric windshield wiper and washer
- Tilt/telescoping steering column
- Cruise control
- Front and roof fresh air vents
- Roll-down, left-side window

- Sliding tinted rear and right-side window
- Door and window locks
- Accessory plug/lighter
- Fire extinguisher
- 19,800 BTU heater/defroster
- Rubber floor mat
- Horn
- Dome light

Cab Instrumentation – Tilt-out (for service access) illuminated instrument panel includes:

- Speedometer with LCD readout for odometer, hour meter, two trip odometers, and a clock
- Tachometer
- Voltmeter
- Stop and check engine warning lights
- Fuel gauge
- Engine oil pressure gauge
- Engine temperature gauge
- Front and rear air pressure gauges with low air pressure warning buzzer/light
- Transmission temperature gauge with overheat warning buzzer/light (available only with automatic)
- Cruise controls

- Engine fan clutch switch
- Heater and defroster controls
- Light controls
- Park brake switch and applied light
- Engine diagnostic request switch

■ Additional Equipment

Standard:

- a Towing shackles front and rear
- Aluminum full deck fenders and ladders
- Outrigger controls with engine throttle-up control
- West coast type rear view mirrors with adjustable convex mirror
- Trailer electrical and air connections
- 2-way reading bubble levels
- Back-up alarm
- Mud flaps
- Air dryer
- Lug wrench
- Tire inflation system

Optional:

- Spare tires and rims

| Engine Specifications | Detroit Diesel Series 60 - 12.7 liter |
|-------------------------|---------------------------------------|
| Number of cylinders | 6 |
| Bore | 5.12" (.13 m) |
| Stroke | 6.30" (.16 m) |
| Piston displacement | 778 cu. in. (12 751 cm ³) |
| Max. brake h.p. @ rpm | 430 (321 kw) @ 2,100 |
| Governed load speed rpm | 2,100 |
| Peak torque @ rpm | 1,450 ft. lbs. (1 966 j) @ 1,200 |
| Alternator | 130 amps |
| Air compressor | 28 cfm (.85 m ³ /min) |

| Axle | Maximum Allowable Load @ 65 mph (105 km/hr) |
|-------|---|
| Front | 43,660 lbs (19804 kg) |
| Rear | 85,840 lbs (38936 kg) |

■ Axle Loads

| Base machine: Standard revolving upperstructure equipped with Isuzu engine, hydraulic backstops, mast, bridle, bail, boomhoist rope with mast to rear of upper and 1,050' (320 m) of front drum rope; Standard carrier equipped with Detroit Diesel Series 60 engine, manual transmission, aluminum fenders, 14R24 front and rear radial tires, full fuel and front center hydraulic jack. | Gross Vehicle Weight | | Upper Facing Rear | | | | Upper Facing Front | | | |
|--|----------------------|-------|-------------------|-------|-----------|-------|--------------------|-------|-----------|-------|
| | | | Front Axle | | Rear Axle | | Front Axle | | Rear Axle | |
| | lbs | kg | lbs | kg | lbs | kg | lbs | kg | lbs | kg |
| | 93,167 | 42273 | 43,933 | 19928 | 49,264 | 22346 | 17,606 | 7986 | 75,591 | 34288 |
| Add Rear Outrigger Box | 13,160 | 5969 | -3,620 | -1642 | 16,780 | 7611 | -3,620 | -1642 | 16,780 | 7611 |
| Add Front Outrigger Box | 11,960 | 5425 | 6,830 | 3098 | 5,130 | 2327 | 6,830 | 3098 | 5,130 | 2327 |
| Add Main Outrigger Floats to Storage Racks | 660 | 299 | 230 | 104 | 430 | 195 | 230 | 104 | 430 | 195 |
| Add Bumper Outrigger Float to Storage Rack | 80 | 36 | 60 | 27 | 20 | 9 | 60 | 27 | 20 | 9 |
| Replace Std Front Tires with 14.00 x 24 Bias Tires | -130 | -59 | -130 | -59 | 0 | 0 | -130 | -59 | 0 | 0 |
| Add Pusher/Lift Axle (Consult factory for effects on axle groups) | 2,250 | 1021 | | | | | | | | |
| Add "A" Bumper Counterweight | 13,500 | 6123 | 17,718 | 8037 | -4,218 | -1913 | 17,718 | 8037 | -4,218 | -1913 |
| Add "B" Bumper Counterweight | 11,500 | 5216 | 15,625 | 7087 | -4,125 | -1871 | 15,625 | 7087 | -4,125 | -1871 |
| Add "C" Bumper Counterweight | 10,000 | 4536 | 13,348 | 6054 | -3,348 | -1518 | 13,348 | 6054 | -3,348 | -1518 |
| Add Driver to Carrier Cab | 220 | 100 | 245 | 111 | -25 | -11 | 245 | 111 | -25 | -11 |
| Remove 1,050 ft of Wire Rope from Front Drum | -1,940 | -880 | -668 | -303 | -1,272 | -577 | 63 | 29 | -2,003 | -909 |
| Add 850 ft of Wire Rope to Rear Drum | 1,700 | 771 | 887 | 402 | 813 | 369 | -357 | -162 | 2,057 | 933 |
| Remove Mast, Bridle, Bail & Boom Hoist Rope | -7,614 | -3454 | -6,342 | -2877 | -1,272 | -577 | 3,966 | 1799 | -11,580 | -5253 |
| Remove Boom Foot Pin Puller | -320 | -145 | -5 | -2 | -315 | -143 | -95 | -45 | -225 | -102 |
| Flip Mast to Front of the Upper | 0 | 0 | 9,101 | 4128 | 9,101 | 4128 | 9,101 | 4128 | -9,101 | -4128 |
| Replace hydraulic backstops w/ rigid (mast over front of upper) | 0 | 0 | 9,101 | 4128 | 9,101 | 4128 | 9,101 | 4128 | 9,101 | 4128 |
| Add "A" Upper Counterweight | 23,000 | 10433 | 18,639 | 8455 | 4,361 | 1978 | -11,462 | 5199 | 34,462 | 15632 |
| Add "B" Upper Counterweight | 19,330 | 8768 | 16,798 | 7619 | 2,532 | 1149 | -10,766 | -4833 | 30,096 | 13651 |
| Add "C" Upper Counterweight | 21,110 | 9575 | 17,422 | 7903 | 3,688 | 1673 | -10,835 | -4915 | 31,945 | 14490 |
| Add 20 ft. Lattice Base Section | 4,647 | 2108 | -1,822 | -826 | 6,469 | 2934 | | | | |
| Add 850 ft Type RB 1' rope to third drum | 2,350 | 1066 | -761 | -345 | 3,111 | 1411 | | | | |
| Add 1050 ft Type RB 1' rope to third drum | 2,280 | 1034 | -598 | -271 | 2,443 | 1108 | | | | |
| Add third drum deflector sheave assembly | 600 | 272 | -462 | -210 | 1,062 | 482 | | | | |
| Add 10 ft Lattice Extension w/ Lifting Sheaves | 2,574 | 1168 | 2,765 | 1254 | 5,339 | 2422 | | | | |

